

Journal of **Electrical Engineering**

Elektrotechnický časopis
ISSN 1335-3632

VOLUME 56, 2005
September - October

9-10



SLOVAK CENTRE OF **IEE**

PAPERS

- Hossein Shayeghi — Heidar Ali Shayanfar:*
Design of Decentralized Robust LFC in a Competitive Electricity Environment 225
- Rastislav Róka — Stanislav Dlháň:*
Modelling of Transmission Channels over the Low-voltage Power
Distribution Network 237
- Michael G. Danikas — Nikolaos Vrakotsolis:*
Experimental Results with Small Air Gaps: Further Thoughts and Comments on
the Discharge(or Charging Phenomena) below the So-called Inception Voltage 624
- Marcel Virág — Justín Murín:*
Thermal Field Simulation of a Tungsten Filament Lamp Referring to its
Lifetime 252
- Nikolay Bankov — Tsvetana Grigorova:*
Load Characteristics and Control System Behavioural Modelling under Optimal
Trajectory Control of Series Resonant DC/DC Converters 258
- Marko Mali — Franc Novak — Anton Biasizzo:*
Hardware Implementation of AES Algorithm 265

COMMUNICATIONS

- Rudolf Kinder — Ladislav Hudec — Marian Blažíček:*
An Automatic Measurement System with Hall Profiling and a Four Point Probe
for Characterization of Semiconductors 270
- Michal Klasovitý — Martin Tomáška — Jaroslav Kováč — František Uherek:*
Software for Microwave Device Models Identification 274
- Milan Žalman — Ivica Kuric:*
Direct Torque and Flux Control of Induction Machine and Fuzzy Controller 278

Elektrotechnický časopis Volume 56, 2005

Published under auspices of SLOVAK CENTRE OF IEE*Editor in Chief:* Daniel Donoval, FEI STU Bratislava, Slovakia*Executive Editor:* Mojmir Kollár, FEI STU Bratislava, Slovakia

Editorial Board

- | | | |
|-------------------------------------------------------|---------------------------------------------------|----------------------------------------------------|
| • Štefan Barta
FEI STU Bratislava, Slovakia | • Ivan Kneppo
TU AD Trenčín, Slovakia | • Eros Passero
Politecnico di Torino, Italy |
| • Igor Bello
City University of Hong Kong | • Mojmir Kollár
FEI STU, Bratislava, Slovakia | • Pavol Podhradský
FEI STU Bratislava, Slovakia |
| • JuraJ Breza
FEI STU Bratislava, Slovakia | • Peter Kordoš
EÚ SAV Bratislava, Slovakia | • Viktor Smieško
FEI STU Bratislava, Slovakia |
| • Daniel Donoval
FEI STU Bratislava, Slovakia | • Štefan Kubíček
IMEC Leuven, Belgium | • Jan Štecha
FEL ČVUT Praha, Czech Rep. |
| • Alexander L. Fradkov
Russian Academy of Sciences | • Štefan Luby
Slovak Academy of Sciences | • Jozef Tlustý
FEL ČVUT Praha, Czech Rep. |
| • Manfred Glesner
TH Darmstadt, Germany | • Karol Marton
FEI TU Košice, Slovakia | • Vojtech Veselý
FEI STU Bratislava, Slovakia |
| • Hans Hauser
TU Vienna, Austria | • Daniel Mayer
FEL ZČU Plzeň, Czech Rep. | • Gerhardt Wachutka
TU München, Germany |
| • Didier Henrion
LAAS-CNRS Toulouse, France | • Antony J Moses
Cardiff University, UK | • Ján Zehentner
FEL ČVUT Praha, Czech Rep. |
| • Hiroshi Iwai
Tokyo IT, Japan | • Miloslav Neveselý
TU Žilina, Slovakia | • Miroslav Zeman
Delft UT, The Netherland |
| • František Janíček
FEI STU Bratislava, Slovakia | • Jozef Novák
EÚ SAV Bratislava, Slovakia | • Branka Zovko-Cihlar
TU Zagreb, Croatia |
| • Zdislaw Kabza
Politechnika Opolska, Poland | • D. P. Papadopoulos
DE& CE DUT Xanthi, Greece | • František Židek
FEI STU Bratislava, Slovakia |

Administration Office: **Ilkovičova 3, 812 19 Bratislava, Slovakia**

tel.: ++ 421 2 602 91 646, ++ 421 2 654 22 783 fax: ++42 2 654 22 756

Published monthly. Propagation, subscriptions and payments accepted by Administration Office.

*Published by:*Faculty of Electrical Engineering and Information Technology
of the Slovak University of Technology, Bratislava

Institute of Electrical Engineering of the Slovak Academy of Sciences, Bratislava

e-mail: jeeec@elf.stuba.sk, <http://iris.elf.stuba.sk/JEEEC/>*Printed at:*

Slovak University of Technology, Nám. slobody 17, 812 43 Bratislava

Typeset in $\mathcal{A}\mathcal{M}\mathcal{S}$ - $\mathcal{T}\mathcal{E}\mathcal{X}$, used `elcas.sty` a modification of `amspt.sty`

©2005 FEI STU Bratislava

*Distribution outside Slovakia and Czech Republic***SLOVART G.T.G.**, s.r.o

Krupinská 4, PO BOX 152, 852 99 Bratislava 5, Slovakia

tel: ++ 421 2 638 39 471-3, 638 30 378, fax: ++ 421 2 638 39 485

e-mail: gtg@internet.sk, <http://www.slovart-gtg.sk>

SOFTWARE FOR MICROWAVE DEVICE MODELS IDENTIFICATION

Michal Klasovity — Martin Tomáška —
Jaroslav Kováč — František Uhrek *

In order to improve and accelerate the microelectronic device models identification, the S-parameter simulation software — SOPT was developed. It uses an unconventional but effective method for the simulation of S-parameters. This method allows to calculate S-parameters related to the real as well as complex reference impedances, which can be different on each port of the simulated circuit. The simulated circuit is optional, given by an input text file. The SOPT software includes effective optimization routines for identification of the equivalent circuits from S-parameter measurements of a given device, measured in a wide frequency range.

Keywords: microwave measurements, model identification, optimization, scattering parameters, SOPT simulator, S-parameter simulation software

1 INTRODUCTION

Simulation is a very effective approach for the design of complex electronic systems. However, simulation of high frequency electronic devices needs reliable models applicable in a wide frequency range. The development of S-parameters simulation software was motivated by the requirement to construct a fast and reliable instrument for automated SPICE models identification by employing S-parameter measurements. This article describes a simulator of scattering parameters, which is the base part of the SOPT model identifier. It uses methods for composition of the complete admittance matrix, its simplification and recalculation to one-port, or two-port microwave S-parameters. The topological structure of the simulated device is described by the input text file (netlist). The netlist can be composed from unlimited amount of basic elements like passive structures, lossy transmission lines, voltage controlled current sources *etc.* The program includes effective optimization algorithms for extraction of the small signal device model parameters from the S-parameters, measured in a wide frequency range. The basic program function, commands description and a simulation example are described below.

2 BASIC OPERATION PRINCIPLE

The calculation of the scattering parameters passes in several steps. First, the topological structure of the input circuit together with the simulation control commands is loaded from the input text file. The elements from a text file are transformed into the list of corresponding data structures (device list), which permits easier processing in opposite to the text representation. During this step the tests for erroneous connections (for example connection

of element terminals into the same node) are tested and a lexical correctness of the control commands is verified, too.

After that the complete admittance matrix (Y-matrix) is created from the device list. Dimension of the created Y-matrix is the same as the number of nodes in the circuit. Y-matrix was used for network representation and S-parameters calculation because it can be directly generated from the netlist by employing the published algorithm [1]. In this step the error check of the floating nodes in the circuit is verified, too. If the error check of the simulated circuit passes successfully, then the complete Y-matrix is reduced to a matrix with dimension 1×1 (1-port simulation) or 2×2 (2-port simulation). The pivot condensation method was successfully employed for this purpose [2].

In the last phase the reduced Y-matrix is transformed to the S-matrix by using one-port (1) and two-port (2-5) transformation equations, derived independently of literature:

$$\Gamma = \frac{1/Y - Z_g^*}{1/Y + Z_g}, \quad (1)$$

$$S_{11} = \frac{(1 - Z_{g1}^* Y_{11})(1/Z_{g2} + Y_{22}) + Z_{g1}^* Y_{12} Y_{21}}{(1 + Z_{g1} Y_{11})(1/Z_{g2} + Y_{22}) - Z_{g1} Y_{12} Y_{21}} \quad (2)$$

$$S_{12} = \frac{-Y_{12}(1 + Z_{g1}^*/Z_{g1})}{(1/Z_{g1} + Y_{11})(1 + Z_{g2} Y_{22}) - Z_{g2} Y_{12} Y_{21}} \sqrt{\frac{\text{Rep}\{Z_{g2}\}}{\text{Rep}\{Z_{g1}\}}} \quad (3)$$

$$S_{21} = \frac{-Y_{21}(1 + Z_{g2}^*/Z_{g2})}{(1 + Z_{g1} Y_{11})(1/Z_{g2} + Y_{22}) - Z_{g1} Y_{12} Y_{21}} \sqrt{\frac{\text{Re}\{Z_{g1}\}}{\text{Re}\{Z_{g2}\}}} \quad (4)$$

$$S_{22} = \frac{(1 - Z_{g2}^* Y_{22})(1/Z_{g1} + Y_{11}) + Z_{g2}^* Y_{12} Y_{21}}{(1 + Z_{g2} Y_{22})(1/Z_{g1} + Y_{11}) - Z_{g2} Y_{12} Y_{21}} \quad (5)$$

* Slovak University of Technology, Faculty of Electrical Engineering and Information Technology, Department of Microelectronics, Ilkovičova 3, SK-81219 Bratislava, Slovakia, michal.klasovity@stuba.sk

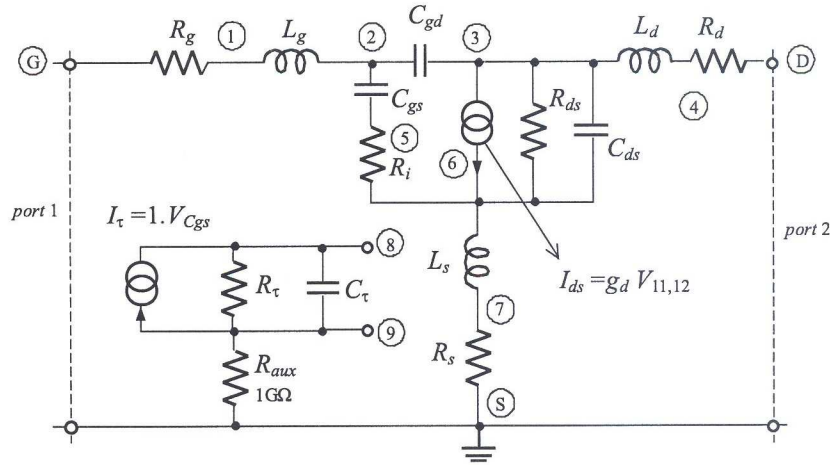

Fig. 1. Schematic diagram of MESFET small-signal model with node numbers.

Table 1. MESFET small signal model parameters calculated from the measured S-parameters.

Parameter	R_g	R_d	R_s	R_{ds}	R_i	L_g	L_d	L_s	C_{gd}	C_{gs}	C_{ds}	g_m	C_τ
Minimum	0.1 mΩ	1, mΩ	1, mΩ	1, mΩ	0.1 mΩ	0.1 pH	0.1 pH	0.1 pH	1 fF	1 fF	1 fF	1 mS	1 fF
Maximum	1 kΩ	1 kΩ	1 kΩ	1 kΩ	1 kΩ	5 nH	5 nH	5 nH	1 pF	1 pF	1 pF	100 mS	10 pF
Start Value	100 Ω	100 Ω	100 Ω	100 Ω	0.1 Ω	100 pH	100 pH	100 pH	40 fF	40 fF	40 fF	10 mS	0.1 pF
Final Value	3.16 Ω	5.76 Ω	2.64 Ω	255.4 Ω	1.3 Ω	30.9 pH	46.3 pH	17.2 pH	24.4 fF	308.1 fF	64 fF	41.7 mS	1.7 pF

where Γ is the one-port reflection coefficient, Y is the one-port load admittance, S_{jk} are simulated S-parameters, Y_{jk} are admittance parameters of the simulated circuit and Z_g, Z_{g1}, Z_{g2} are complex reference impedances at appropriate ports.

In complete simulation the Y-matrix must be composed, reduced and recalculated to the S-matrix for each frequency point, hence these steps were optimized in order to reduce the computational time.

3 SMALL SIGNAL DEVICE MODEL IDENTIFICATION ROUTINES

The SOPT software creation was motivated mainly by the effort to simplify identification of the SPICE device models from S-parameter measurements. Two effective optimization methods were implemented into the program for this purpose: the simplex optimization method [3] and the genetic algorithm [4] with two different kinds of selecting operators (the roulette wheel selector and the tournament selector). These algorithms were chosen and implemented due to their robustness and insensitivity to local extremes. The identified model topology is defined in the netlist. The netlist must also contain the definition of the sought variable model parameters and specification of an input file containing the measured S-parameters which correspond to the modelled device. The main goal of the optimization process is to change the variable model parameters by a chosen optimization algorithm in order to minimize deviation between the measured and modelled S-parameters. This deviation is expressed by the cost

functions (6) for a one-port device and (7) for a two-port device:

$$Q_1 = \frac{1}{N} \sum_{i=1}^N w_i \cdot \frac{|\Gamma_{Mi} - \Gamma_{Ci}|}{|\Gamma_{Mi}|} \quad (6)$$

$$Q_2 = \frac{1}{N} \sum_{i=1}^N \left(w_{11i} \frac{|S_{11Mi} - S_{11Ci}|}{|S_{11Mi}|} + w_{12i} \frac{|S_{12Mi} - S_{12Ci}|}{|S_{12Mi}|} + w_{21i} \frac{|S_{21Mi} - S_{21Ci}|}{|S_{21Mi}|} + w_{22i} \frac{|S_{22Mi} - S_{22Ci}|}{|S_{22Mi}|} \right), \quad (7)$$

where N is the number of measured frequency points, w_i and w_{jki} are the weight coefficients advancing S-parameters in a specific frequency range, $\Gamma_{Mi}, \Gamma_{Ci}, S_{jkMi}$ and S_{jkCi} are the measured and computed S-parameters at appropriate frequency point i . The optimal solution, when the chosen device model best approximates the measured data is at the global minimum of the cost function (6) or (7).

4 CIRCUIT TOPOLOGY DEFINITION AND SIMULATION CONTROL COMMANDS

The netlist syntax is similar as used in the HSPICE simulator. Up to now five basic device models have been implemented in the actual program version: a resistor, a capacitor, an inductor, a lossy transmission line and a voltage controlled current source. However, other basic element models may be simply added into the SOPT program. The program contains also commands for simulation frequency range specification, output results format

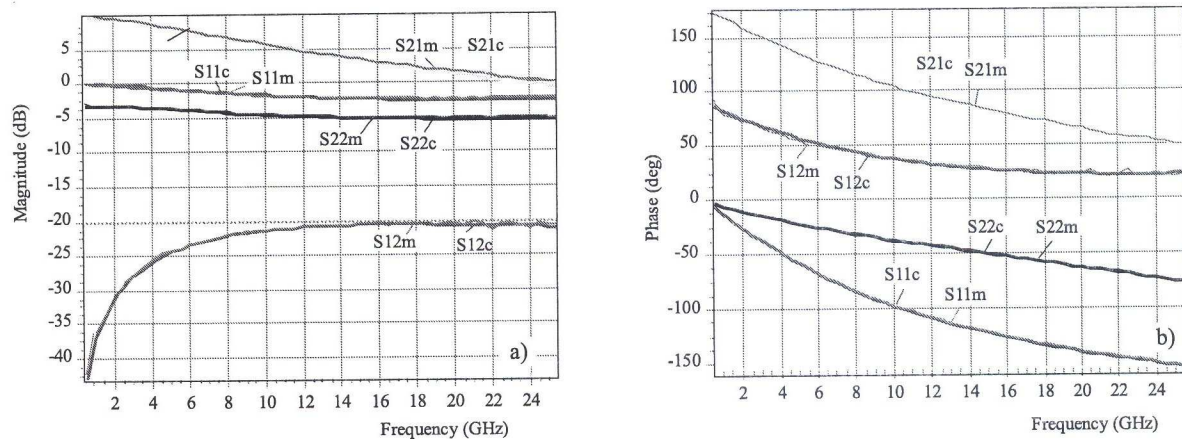

Fig. 2. Measured and simulated S-parameters of MESFET a) magnitude, b) phase.

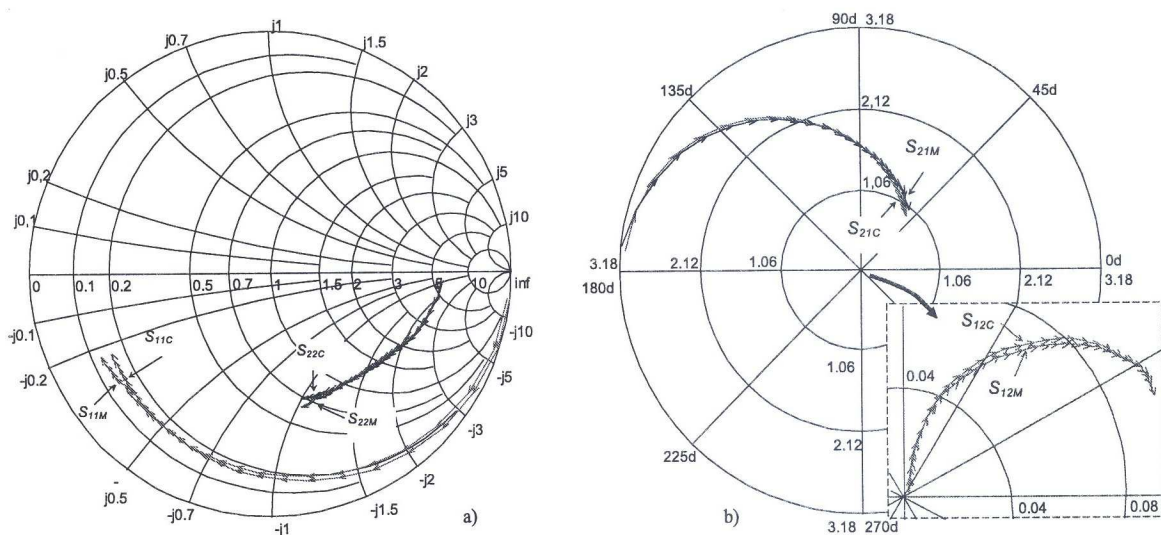

Fig. 3. Measured and simulated S-parameters of MESFET shown in a) Smith chart, b) polar chart. Frequency points are marked in the range 500 MHz – 25.5 GHz with the step of 1 GHz by arrows.

selection, optimization setup *etc.* Detailed description of the circuit topology definition, simulation control commands and other important information may be found at the web page [5].

5 APPLICATION EXAMPLE

As an example, MESFET small-signal model identification is performed. The schematic diagram of the used model is shown in Fig. 1. This includes thirteen unknown model parameters calculated from the measured S-parameters in the frequency range 500 MHz up to 25.5 GHz with step of 500 MHz. The key task of the simulation process is an error free netlist creation [5]. This can be written in an optional text editor or directly in the SOPT environment. For the simulation example 1355 iteration steps were needed to find the unknown model parameters. The initial values, boundary conditions and final results are summarized in Tab. 1. The magnitude and phase of the measured and calculated S-parameters,

drawn by the software in rectangular charts as well as in Smith and polar charts are shown in Fig. 2 a, b and Fig. 3 a, b. The maximal deviation between the measured and simulated S-parameters is lower than 0.2 dB for magnitude and 2 degrees for the phase in the frequency range 500 MHz – 18 GHz. The measurement test set error in the specified frequency range is higher than the maximal deviation between the measured and simulated S-parameters. For frequencies over 18 GHz the deviation between the measured and simulated coefficient S_{21} exceeds the test set measurement error.

6 FUTURE DEVELOPMENT

Another important basic element models will be implemented into the program in the future (for example the lossy transmission line with skin effect and dielectric material polarization consideration). The SOPT program will be extended by routines for automated large signal SPICE device models extraction.

7 CONCLUSION

The internal structure, properties and an application example of the S-parameter simulator have been described. The presented software allows to calculate S-parameters in the specified frequency range. Simulated S-parameters can be related to complex reference impedances, which need not to be the same at all ports. However, the main program feature is the ability to identify a small signal device model from microwave S-parameter measurements. Progressive optimization methods implemented in the program ensure robustness, reliability and insensitivity to local extremes. Correct program function was tested by identification of a small signal MESFET model. Simulated results proved the correctness of the used methodology. The maximum deviation between the measured and simulated S-parameters is under the measurement precision of the test equipment up to 18 GHz. The extracted small signal MESFET model is valid in the specified frequency range. The program is used for research and educational purposes.

Acknowledgement

This work was supported by projects No. AV/806/2002, APVT-20-013902 and VEGA 1/0152/03.

REFERENCES

- [1] CHUA, L. O.—LIN, P. M.: *Computer-Aided Analysis of Electronic Circuits*, Prentice-Hall Inc., Englewood Cliffs, New Jersey, 1975.
- [2] PODHRADSKÝ, P.—KOTULIAKOVÁ, J. *Computer-Aided Design of Electronic Circuits (Návrh obvodov počítačom)*: Slovenská technická univerzita, Bratislava, 1993. (in Slovak)
- [3] ČERNOHORSKÝ, D.—RAIDA, Z.—ŠKVOR, Z.—NOVÁČEK, Z.: *Analysis and Optimization of Microwave Structures (Analýza a optimalizace mikrovlnných struktur)*, Vysoké učení technické v Brně, 1999. (in Czech)
- [4] KVASNIČKA, V.—POSPÍCHAL, J.—TIŇO, P.: *Evolutionary Algorithms (Evolučné algoritmy)*, Slovenská technická univerzita, Bratislava, 2000. (in Slovak)
- [5] KLASOVITÝ, M.: *The Simulator of Scattering Parameters with Integrated Identifier of Microwave Device Models*, <http://aladin.elf.stuba.sk/~klasovit/sopt/index.php>, last updated 12.04.2005.

Received 12 April 2005

Michal Klasovitý (Ing) born in Myjava, Slovakia, in 1977. Graduated from the Faculty of Electrical Engineering and Information Technology, Slovak University of Technology, Bratislava, in 2001. At present he is a PhD student at the Department of Microelectronics, Faculty of Electrical Engineering and Information Technology. The main fields of his research and teaching activities are microwave measurements, computer aided circuit analysis and optimization methods.

Martin Tomáška (Ing, PhD) born in Handlová, Slovakia, in 1955. Graduated from the Faculty of Electrical Engineering, Slovak Technical University, Bratislava, in 1979. He received the CSc (PhD) degree in 1995 from STU Bratislava. At present he is a lecturer at the Department of Microelectronics, Faculty of Electrical Engineering and Information Technology. The main fields of his research and teaching activities are optoelectronics and microwave electronics.

Jaroslav Kováč (Prof, Ing, PhD) was born in Šafárikovo, Slovakia, in 1947. He graduated from the FEI STU, Bratislava, in 1970. Since 1971 he has been engaged in the research of optoelectronic devices technology at the Microelectronics Department of FEI STU. He received a CSc (PhD) degree from STU Bratislava, in 1983. Since 1991 he has been the team leader of the Optoelectronic and microwave group at the Department of Microelectronics.

František Uherek (Prof, Ing, PhD) was born in Zlín, Czech Republic, in 1954. He received the Ing (MS) and CSc (PhD) degrees from FEI STU, Bratislava, in 1979 and 1989, respectively. In 1980 he joined the Microelectronics Department of FEI STU. At present he is full professor and vice-head of the department. His main interests are optoelectronics, optoelectronic devices and their applications.